

Ortles

Inspection slitter rewriter
for average/long runs from
flexo, offset or inkjet

MAIN FEATURES

- BOSCH REXROTH electronics, servo drive motors on nip roll and rewinders
- Servo driven 800mm unwinder with Energy recovery, for a significant cost saving
- Webguide with ultrasonic sensor
- Rewinding speed up to 350m/min
- Display 10" color touch screen with step by step instructions
- Storable job recipes with quick recall by name, customer and favourites
- Remote service and production data export
- Stop production with label counter, length and final diameter
- Automatic stop at unwinder end of roll
- Ultrasonic label counter
- 2 in 1 slitting system, to pass from rotary to razor in few minutes with no additional devices
- Rewinder with servo drive motorization
- Available size 330mm, 430mm, 530mm

AVAILABLE OPTIONS

- Second rewriter with independent servo drive motorization
- LAVAREDO automatic slitter positioning system for both rotary and razor
- 100% inspection system
- Waste rewriter with inverter motorization
- Motorized trim extractor synchronized with web movement
- Marcatore inkjet per dati variabili, datamatrix ecc
- Expandable shafts from 0,5" to 6"
- Longitudinal razor slitting unit
- Full rotary die cut unit EIGER

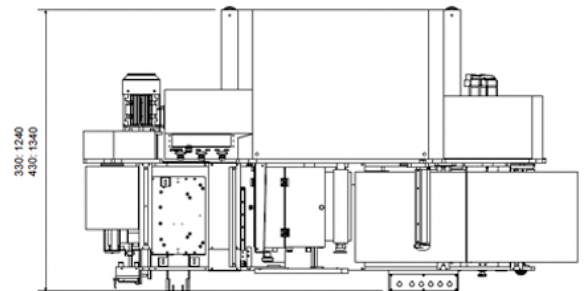
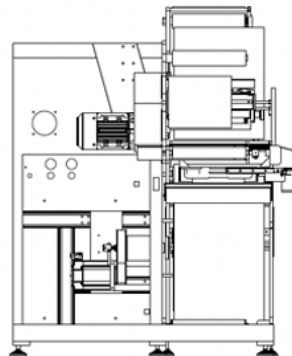
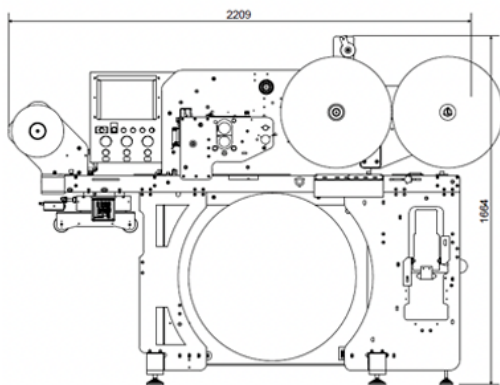

Labeltech sas di Gabriele D'Onofrio & C.
Via per Turbigo, 17 - 20022 Castano Primo (MI) Italy
Tel. +39 0331 882289 · info@labeltech.it labeltech.it

